

Franke Coffee Machines.
Saphira:
The art of enjoying coffee.



Saphira: For those who understand a thing or two about coffee.

And now for a splendid cup of coffee! A strong espresso, with that authentic Italian taste? Or a frothy cappuccino, just as you might find in a charming Parisian café? When space is at a premium, the Saphira from Franke has everything the coffee connoisseur could wish for. This neat unit is fully automatic, easy to program, and the only compact machine that's as versatile as a large fully automatic professional unit. After all, good things come in small packages. Like all Franke coffee machines, the Saphira excels in one particular area:

The art of excellent coffemaking.



The useful extras.



If required, the coffee-bean containers can be expanded to 500 g capacity each. Both containers can be locked.



The use of commercially available billing and dispensing systems such as coin validators and/or card scanners is provided for and integrated in the design. A 3 litre water tank is incorporated into the compact design.



The permanent mains water connection is extremely simple to fit or retrofit, and can be used for both water containers (5.5 litres and 3 litres).



The coffee machine is programmed directly by the user via the programming panel; the settings are confirmed by the display readings.

Options for the Saphira

- Permanent mains water connection
- Drainage for drip tray
- Coffee-bean container extension to 2 x 500 g
- Coffee grounds chute
- Cool box unit for milk storage
- Water treatment units
- Billing systems

System-based milk preparation

The cappuccinatore – already included in the Saphira standard equipment – is directly integrated into the coffee machine's dispenser system, which means you can dispense coffee and milk foam simultaneously. So the ever popular cappuccino is whisked into the cup in an instant.

The cool box unit stores the milk at a constant temperature, keeping up to 2 litres of milk fresh for an extended period. The milk in the chromium steel container is topped up by lifting the lockable lid of the cool box unit.

The automatic rinsing and cleaning programme makes a perfect impression, ensuring the milk is processed under totally hygienic conditions at all times.

The cappuccinatore is rinsed automatically after a pre-programmable period of time. The supply pipes and the cappuccinatore are easily accessible and can be changed by the customer if the need arises.

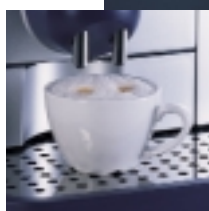

Saphira: Good coffee, good business.

Satisfied staff are simply more productive. So why not treat them to the cutting-edge technology of Franke coffee machines? In hairdressing salons, office pools, small and medium-sized companies, snack corners in large companies, agencies or even large-scale catering firms: A cup of coffee from the Saphira is as unmistakable as a masterpiece. And satisfies staff and customers alike.

The art of excellent coffeemaking.



Saphira: Perfection in design and technology.



Operating panel

Easy operation and very simple programming are the characteristic features of the Saphira. With its generously sized operating panel with its five product buttons, the unit is also ideally suited for self-service operation. The buttons can be individually fitted with whatever product buttons are required. The large LED display guides the user through the operating steps. Two additional buttons are available for dispensing hot water and steam.

Programming

Programming by the customer is carried out directly on the unit by means of the programming panel and is confirmed by display messages. With its two additional product buttons for small coffee jugs and milk foam, the Saphira offers an even wider range of features.

Cleaning/descaling

The integrated, fully automatic rinsing, cleaning and descaling programme for the coffee and milk unit facilitates the maintenance and care of the coffee machine, and ensures optimum hygiene and a consistently high coffee quality.

Dispenser area

With the stepless height adjustment of the coffee / milk dispenser from 75 to 155 mm, you can use all the popular sizes of cups and containers. The optimised coffee supply system and dispenser guarantee that the coffee is always at the ideal temperature and that cups are filled evenly when using the double-dispenser system. The dispenser is extremely easy to dismantle and be cleaned in a dishwasher without any problem.

Standard features

- Two precision grinders with direct grinding for two types of coffee beans
- Coffee and foam from the same dispenser at the touch of a button
- Integrated cappuccinatore for the frothiest milk foam
- Simultaneous dispensing of coffee and hot water/steam at separate dispensers
- Adjustable dispenser for all types of cups (75 – 155 mm)
- Fresh water tank, 5.5 litre capacity
- Clearly arranged operating panel with large LED display
- Dry coffee grounds ejected into tray, with overflow safeguard

A neat piece of work.

Choose from different outstanding coffee specialities, freshly ground and brewed. The ideal machine does more than increase your enjoyment – it also helps to save time and money, with every product made quickly at the touch of a button.

From Franke, of course.

The Saphira is the fruit of Franke's many years of experience in designing professional coffee machines. Built to Franke's proven quality standards, it is dependable and durable, for a quick return on investment. The Saphira is rounded off with a multitude of options to suit every application.

And finally:

The Saphira's size and output make it unique in the market.

Saphira – the compact professional coffee machine.

Saphira: Facts & Figures.

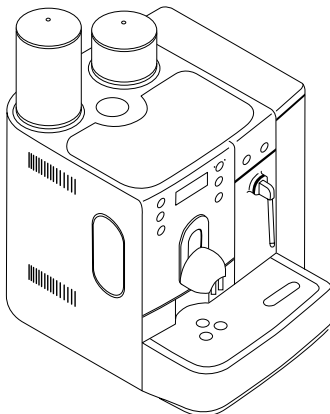
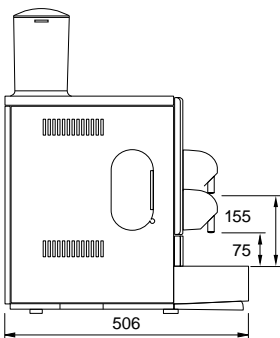
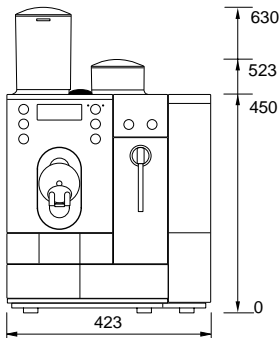

Standards:

- High-performance piston coffee machine with pre-infusion
- 2 high-precision grinders with direct grinding
- Individual grinder selection, with ground coffee blended for each product
- Coffee-bean level monitoring
- Controlled quantity of hot water output
- Steam dispenser for separate milk heating
- Operating panel with 5 product buttons
- Programming area with 2 additional product buttons
- Individual programming of the water, ground coffee and milk quantity for each product
- 2 separate brewing temperatures
- Automatic rinsing, cleaning and descaling programme for coffee and milk unit
- Adjustable combined dispenser 75 to 155 mm
- Dry coffee grounds ejected into tray, with overflow safeguard
- 2 heating systems: coffee and hot-water dispensed simultaneously
- Integrated cappuccinatore
- Direct dispensing of coffee and milk foam at the touch of a button
- Provision for connection to dispensing and billing systems
- Colour: midnight blue/silver

Dimensions	W = 423 mm, D = 506 mm, H = 523 mm above bean container
Weight	18 kg
Electrical connection	1 x 230 V AC, 2.3 kW, 10 A
Water supply	Side water tank, 5.5 litre capacity. Permanent connection to water mains (optional)
Residual water	Drip tray with monitoring, 1.5 litre capacity. Fixed drain (optional)
Bean container	2 containers, 250 g each
Grounds container	40 cakes
Daily output	The unit is designed to handle an average daily output of approx. 100 cups
Spot output	2 cups of espresso/cappuccino/hot water per minute